

HMC002 Series

Pneumatic Module

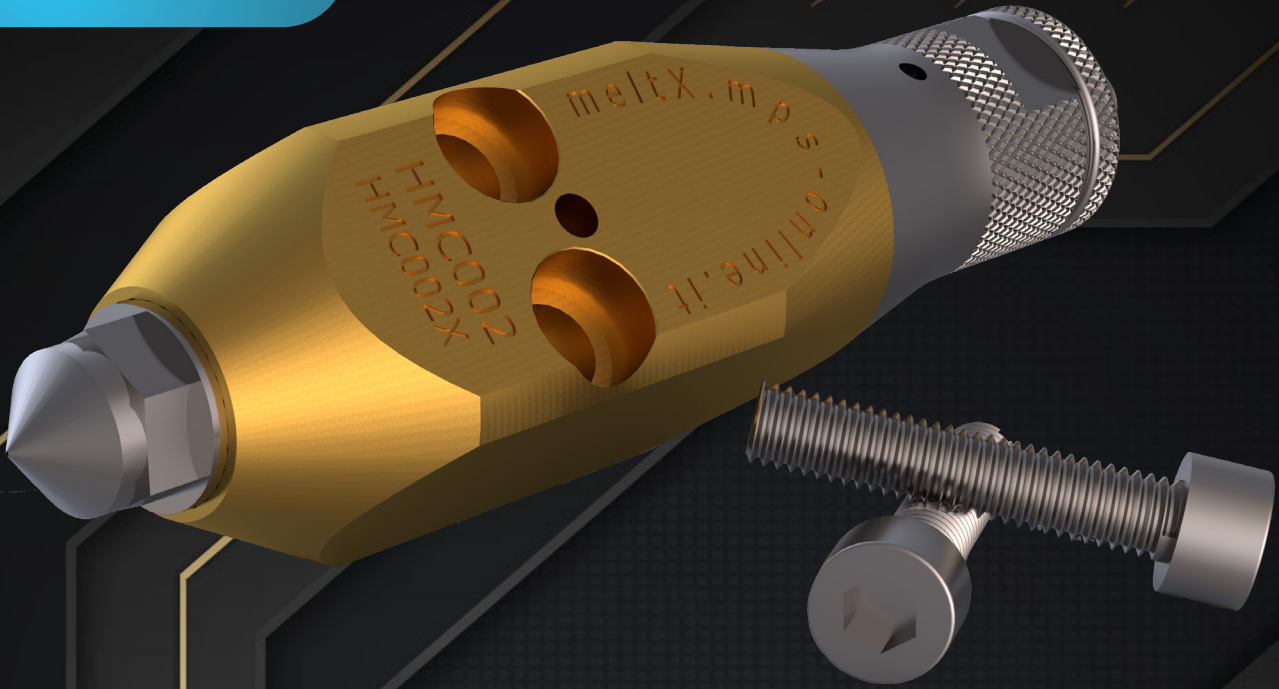

HMC002 Represent our state of art for mechanical Hi-end Industrial grade hot melt module. Built for standard industrial application, ensure no glue leak, long life and high speed. Compatible with old Gun Systems and new Zero Lock Guns Z20

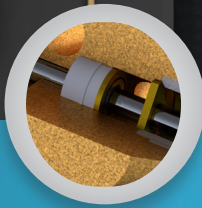

70 Bar Gasket

A Powerful Gasket made to work at high speed up to 70 Bar pressure. Material in compliance with food markets



Long Life Badge

The Module Body, spring, and gaskets are made to be resistant to daily work in continuous applications.

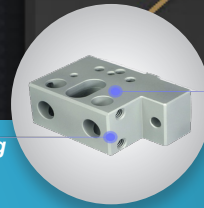

Corrosion Free

Non Polluting

Aerospace Materials

Working every day in high tech markets, our group designed all component in high tech materials and treatments. All the gun is made in Ergal Aluminium with Heavy oxidation.



HMN Nozzle compatible

Our HMC002 Series is compatible with a complete line of nozzle, from standard to carbide nozzle for a perfect glue control

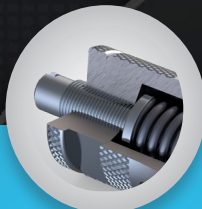

Micro Counting

With a fine pitch micro counting regulation customers will be able to fine set module response in high speed applications



No dispencing leak

The complete Italian manufacturing machining of all parts of our module ensure the complete absence of glue during shut time of module.

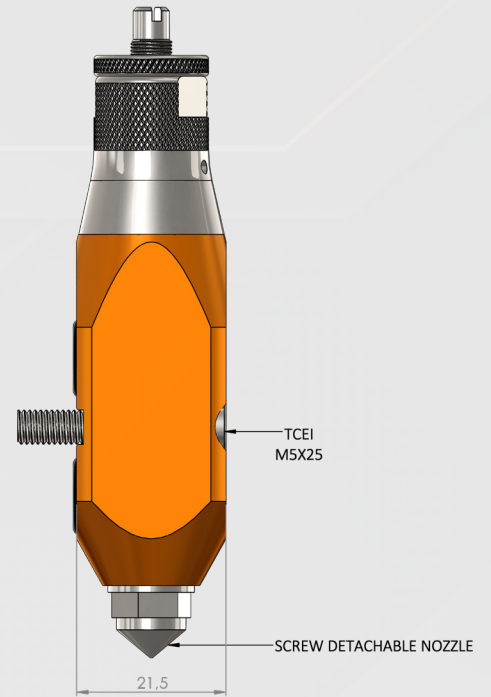
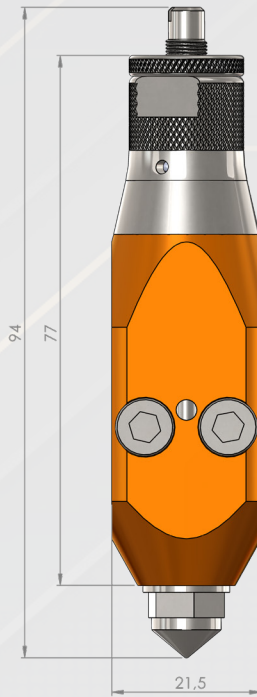
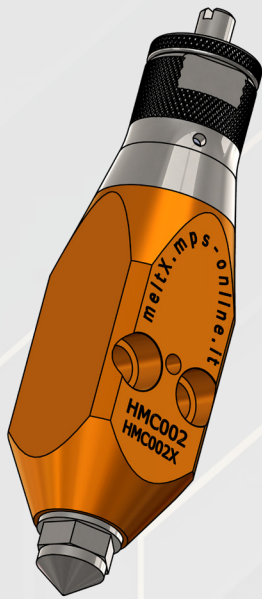

THECNICAL SPECIFICATIONS

VERSION	HMC002	HMC002X
WEIGHT	105 gr	180 gr
MATERIAL	Ergal	1.4404
LOCK SYSTEM	FLS (Form lock System) + 2 X M4 / M5 Screw TCEI	
ADESIVE TYPE	Up to 120000 Cps	
WORKING TEMP	45 - 235 °C	
NOZZLE	0.2 to 1.2 mm - One or more holes	

PNEUMATIC SPECIFICATIONS

MAX PRESSURE	7 Bar
VALVE VOLTAGE	24V
ADESIVE PRESSURE	70 Bar
SPEED CYCLE	4000 Cycle / Min

NOZZLE COMPATIBILITY



Copyright 2021 - MPS S.r.l. - All Right Reserved - Data can change without any notice

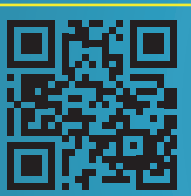

Visit us:
Meltx.mps-online.it
 Call Us:
 +39 0143 343 595
 Write Us
info@mps-online.it

